

A R T E R Y

Association for Research into
Arterial Structure and Physiology



ARTERY 22

20-22 October 2022
Centre de Congrès Prouvé
Nancy, France
www.arterysociety.org



ORGANISING COMMITTEES

ARTERY EXECUTIVE COMMITTEE

President:	Professor Thomas Weber	Wels	Austria
Vice President:	Dr. Carmel McEniery	Cambridge	UK
Secretary:	Professor Pedro Cunha	Guimarães	Portugal
Treasurer:	Professor Chakravarthi Rajkumar	Brighton	UK
Ordinary Members:			
	Dr. Rosa Maria Bruno	Paris	France
	Dr. Janos Nemcsik	Budapest	Hungary
	Dr. Bart Spronk	Maastricht	Netherlands
	Dr. Dimitrios Terentes-Printzios	Athens	Greece

ARTERY COUNCIL MEMBERS

Professor Alun Hughes (Chair)	UK	Professor Ian Wilkinson	UK
Professor Stephane Laurent	France	Professor Reuven Zimlichman	Israel
Dr Gary Mitchell	USA	Peter Nilsson	Sweden
Dr Koen Reesink	The Netherlands	Rachel Climie	France
Professor Patrick Segers	Belgium	Andrea Guala	Spain
Professor James Sharman	Australia	James Cameron	Australia
Professor Siegfried Wassertheurer	Austria	Areti Triantafyllout	Greece

ARTERY ADVISORY BOARD

Professor Charalambos Vlachopoulos	Greece
Professor Kennedy Cruikshank	UK
Professor Pierre Boutouyrie	France

ARTERY 22 LOCAL ORGANISING COMMITTEE

Dr Patrick Lacolley & Dr Véronique Regnault, Nancy, France

THE ARTERY SOCIETY

The concept that vascular age is better related to prognosis than chronological age is rapidly evolving. Stiffening of arteries, an important element of vascular ageing, is a potent cardiovascular risk prognosticator and emerges as an appealing therapeutic target. “Premature vascular ageing” is genetically determined but it is also associated with cardiovascular risk factors, such as diabetes and hypercholesterolaemia and is modified by several pharmacological and non-pharmacological means, such as nutritional products and lifestyle habits. Furthermore, significance of central haemodynamics is now appreciated beyond the pathophysiological level to risk determination and therapy. Therefore, methods of assessing arterial stiffness and central haemodynamics are important in the modern management of cardiovascular disease, both in terms of risk assessment and therapeutics.

Conference

The ARTERY Society promotes the advancement of knowledge and dissemination of information concerning the pathophysiology, pharmacology, epidemiology, detection, investigation and treatment of arterial structure and function.

Our annual conference covers fully the expanding list of topics relating to large artery structure and function through keynote lectures, lively debates, presentations of peer-reviewed abstracts and practical demonstrations. The conference offers plenty of opportunities for scientific interaction and discussions with dedicated scientists in the field.

Collaboration is key to the success of the ARTERY 22 conference and will serve to both strengthen existing collaborations and help establish new ones in the future.

Membership

Membership of ARTERY is open to anyone active in the field of haemodynamics and large artery structure and function and who usually has had experience in the field of arterial structure and physiology.

The Artery Advisory Board

The Advisory board consists of the past three ARTERY Presidents who advise and support the Executive and Council in a non-voting capacity.

The Artery Council

The Council is made up of up to 30 key opinion leaders, including members of the Artery Executive Commitcentres presenting research centres throughout Europe, and the world. The Council supports the work of the Executive Committee, and their role includes proposing topics for future annual scientific meetings, reviewing scientific papers for Artery Research and assisting with the review of abstracts submitted for the annual scientific meeting.

INVITATION

Dear Colleague,

We are pleased to invite companies with an interest in the field of large artery structure and function to participate as exhibitors at **ARTERY 22** which will be held from Wednesday 19 to Saturday 22 October 2022 at the Prouvé Congress Centre, Nancy, France.

Our 22nd ARTERY conference continues to focus on all aspects of arterial structure and function. All organisations representing relevant aspects of basic and clinical science are welcome – imaging, bioengineering, haemodynamics, epidemiology, pharmacology, treatments, preventive measures etc. Other aspects include biochemical mediators, lipids and inflammation, and we also welcome companies focusing on these areas.

The conference is a prime opportunity to establish new collaborations and network with a highly informed, friendly audience from various backgrounds. Colleagues from sister societies in North America ([North American Artery](#)), Latin America ([LATAM Artery](#)), Asia ([Pulse of Asia](#)) and Australia join us, with particular attention for Young Investigators who will present free communications and many invited lectures.

The Prouvé Congress Center is a state-of-the-art facility, located in the city center, 1 min walk from Nancy TGV station and the public transport platform.

As exhibitors, you will have many opportunities to meet conference participants, particularly during the refreshment breaks and the Networking Welcome Reception at the end of day one.

Your ongoing support is key to the success of our conference. We would urge you to consider the excellent opportunities enclosed in this prospectus which have been designed to work around and support your marketing objectives. If the options do not necessarily meet those objectives, please don't hesitate to contact the Conference Secretariat (artery@conferencecollective.co.uk) in the first instance who will be pleased to discuss alternative options.

It is our intention to offer a stimulating scientific atmosphere in which you can meet old colleagues, make new friends and contacts, inspired by the beautiful city of Nancy,

On behalf of the ARTERY Executive Committee and the ARTERY 22 Local Organising Committee, we look forward to welcoming you to Nancy in October 2022.



Thomas Weber
President of ARTERY

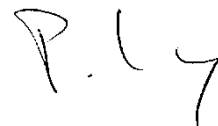

Patrick Lacolley
Chair, Local Organising Committee
ARTERY 22

ARTERY EVENTS

WHO ATTENDS?

Consultants, associate specialists and training grades specialising in cardiology, clinical pharmacology, hypertension and vascular research will attend in addition to biomedical engineers working on arterial structure and function.

WHERE FROM?

The meeting is host to delegates from all over the world, but primarily Europe, with a record 40 countries spanning all continents attending past conferences.

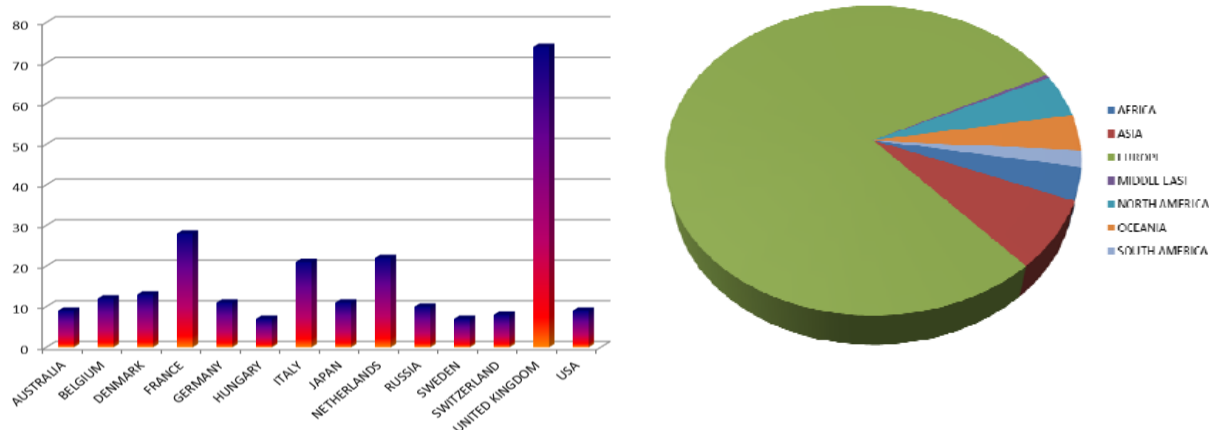

ABSTRACT SUBMISSIONS

Free communications play an important role in the ARTERY Scientific Programme. Abstracts are welcome for consideration for oral or poster presentations dealing with clinical research, experimental studies, epidemiology, biomechanical, methodological, and genetic research related to large artery structure and function. The number of abstracts submitted over the last ten years has steadily increased and we are pleased to report that we have received over 120 abstracts for ARTERY 22.

PRELIMINARY PROGRAMME

WEDNESDAY 19 OCTOBER 2022

14.30	Registration opens
16.00 – 18.00	Masterclasses The management of patients with heart failure: the present and the future, Faiez Zannad Discovery and translationnel science in atherosclerosis, Jean-Baptiste Michel Methodological approaches of arterial stiffness in humans, Rosa-Maria Bruno
16.00	Executive Committee Meeting
17.00	Scientific Council Meeting
18.00	Lecture - Resolution of vascular inflammation, resolving pathways, Magnus Bäck
18.30	Break + exhibition opening
18.45	Editorial Board Meeting Artery Research

THURSDAY 20 OCTOBER 2022

07.00	Registration
08.30	COST Action VascAgeNet
09.30	Special session: Position paper: PWV in clinical practice Athanasios Protogerou / Charalambos Vlachopoulos / Thomas Weber
10.30	Break + Exhibition Viewing
11.00	Welcome address
11.15	Lecture - Novel molecular pathways for discovering stiffness-targeted drugs, Pierre Boutouyrie
11.45	Oral Session I (Young investigator award 1)

THURSDAY 21 OCTOBER 2022 CONTINUED...

12.45	Role of perivascular adipose tissue on arterial function and structure, Marisol Fernandez-Alfonso
13.15 13.45	Lunch Facilitated Poster & Exhibition Viewing
14.30	Relationships between components of blood pressure and cardiovascular events in patients with chronic coronary syndromes and Hypertension: Does arterial stiffness explain the J-curve? Emmanuelle Vidal Petiot
15.00	Career development lectures Agne Laucyte-Cibulskiene, Froso Sophocleous, Ryan Pewowaruk
16.00	Refreshments, poster and exhibition viewing
16.30	Joint Session with LATAM Artery, North American Artery, Pulse of Asia, Alexandre Vallee
17.00	Artificial intelligence and vascular hemodynamics
	Coronary artery disease diagnosis by artificial neural networks, to be confirmed
	Machine learning for assessment of vascular ageing, Vasiliki Bikia
	Estimating PWV from the radial waveform using AI & Machine learning, to be confirmed
17.30	Sex-specific differences in the outcomes of abdominal aortic aneurysms, Janet Powell
18.00	Moderated poster session 1 and welcome networking reception - science and wine
20.00	ARTERY Young investigator networking evening

FRIDAY 21 OCTOBER 2022

07.00	Artery 22 Run
07.00 08.00	Registration Refreshments, Poster and Exhibition viewing
08.30	Oral Session II joint ECCR/Artery
10.00	Moderated Poster Session 2
10.45	Refreshments, Poster and Exhibition viewing
11.15	Lecture in memory Nico Westerhof
11.45	Oral Session III from submitted abstracts (Young investigator award 2)
12.45	Lunch & Exhibition Viewing
13.15	Young Investigator Session
14.15	Oncology and CV complications
15.15	Refreshments, Poster and Exhibition viewing
15.45	Oral session IV
16.45	Focus update: The gut-stiffness axis
17.15	Neutrophil extracellular traps and thrombosis, Kimberley Martinod
17.45 – 18.45	ARTERY Annual Business Meeting
19.00	Break
20.00	ARTERY Conference Dinner with award ceremony

SATURDAY 22 OCTOBER 2019

08.00 08.30	Registration Refreshments, Poster and Exhibition viewing
09.00	Update: Cuffless BP monitoring: ready for prime time ?
10.15	Focus update: all young investigators
10.45	Refreshments, Poster and Exhibition viewing
11.15	Oral Session V
12.15	McDonald Lecture
12.45	Lifetime Achievement Award
13.05	Concluding remarks and close of conference
13.20	Light lunch followed
14.15	End of Conference

VENUE AND LOCATION

Prouvé Congress Centre, Nancy, France



Address: 1 Republic Square, 54063 Nancy, France

Telephone: [+33 3 83 30 80 00](tel:+33383308000)

Website: <https://destination-nancy.com/nos-equipements/le-centre-prouve/>

TRAVELLING TO NANCY, FRANCE

Location of the Prouvé Congress Centre

Its location a few steps from the train station and in the city center makes the Palais des Congrès de Nancy a privileged gateway to the Nancy conurbation.

Train

Paris to 90 min 10 commuting TGV. Direct connections Lorraine TGV station with London, Stuttgart, Frankfurt, Roissy, Lille, Nantes, Bordeaux.

Car

A31 (E21): Northern Europe and Spain via Lyon and Marseille. > A4 (E50 / E25): Paris, Berlin, Stuttgart, Vienna. > Fast track N4 Paris Strasbourg.

Plane

Metz-Nancy-Lorraine regional airport 30 min> Luxembourg international airport 75 min> Nancy-Essey business airport 10 min.

Please see below some hotels to stay for ARTERY 22 conference:

[ibis Nancy Centre Gare et Congrès](#) ***

Distance from Conference Centre: 3 minute walk

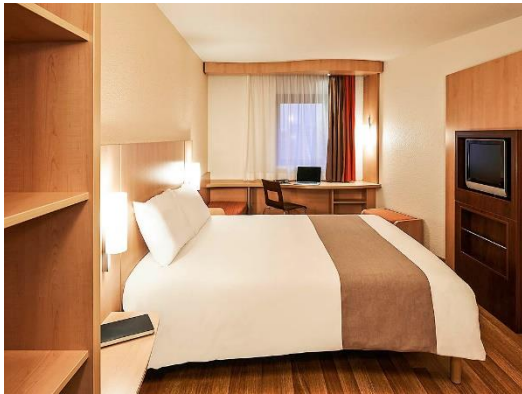

[Mercure Nancy Centre Gare](#) ****

Distance from Conference Centre: 4 minute walk

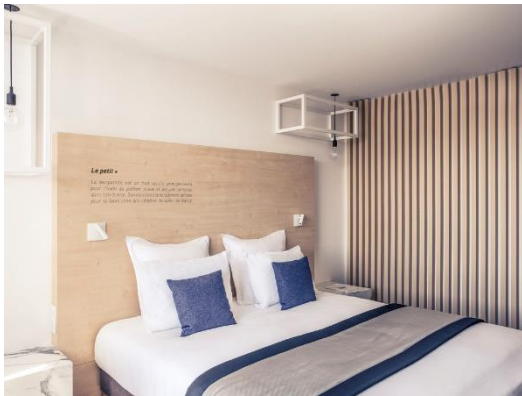

[Mercure Nancy Centre Place Stanislas](#) ****

Distance from Conference Centre: 8 minute walk



You can find a variety of hotels to suit your budget on www.booking.com

SPONSORSHIP & EXHIBITION OPPORTUNITIES

REASONS TO SUPPORT ARTERY 22 CONFERENCE

- Sponsorship gives you the opportunity to build on your relationship with existing contacts and generate new collaborators.
- Artery 22 provides an unmissable opportunity to contribute to key areas of debate and increase your company profile, product awareness and knowledge among your target audience.

There is a wide range of options for your company to become involved in the event, which can be found on the following pages in this brochure. If the packages and opportunities details do not necessarily meet your company's specific marketing objectives, please don't hesitate to contact the Conference Secretariat (artery@conferencecollective.co.uk) to discuss tailor-made packages.

Friends of ARTERY - €3,750

Package includes:

- Exhibition space with one table and two chairs
- Lunch and refreshments throughout the conference
- Attendance at Welcome Networking Reception for 2 company personnel
- 2 Conference Dinner tickets for Conference Dinner
- Recognition as a Friend of Artery on conference publicity and website
- Exhibition space (3m x 2m) including a table and two chairs
- 2 registrations for company personnel
- Access to scientific sessions

EXHIBITION FLOOR PLAN

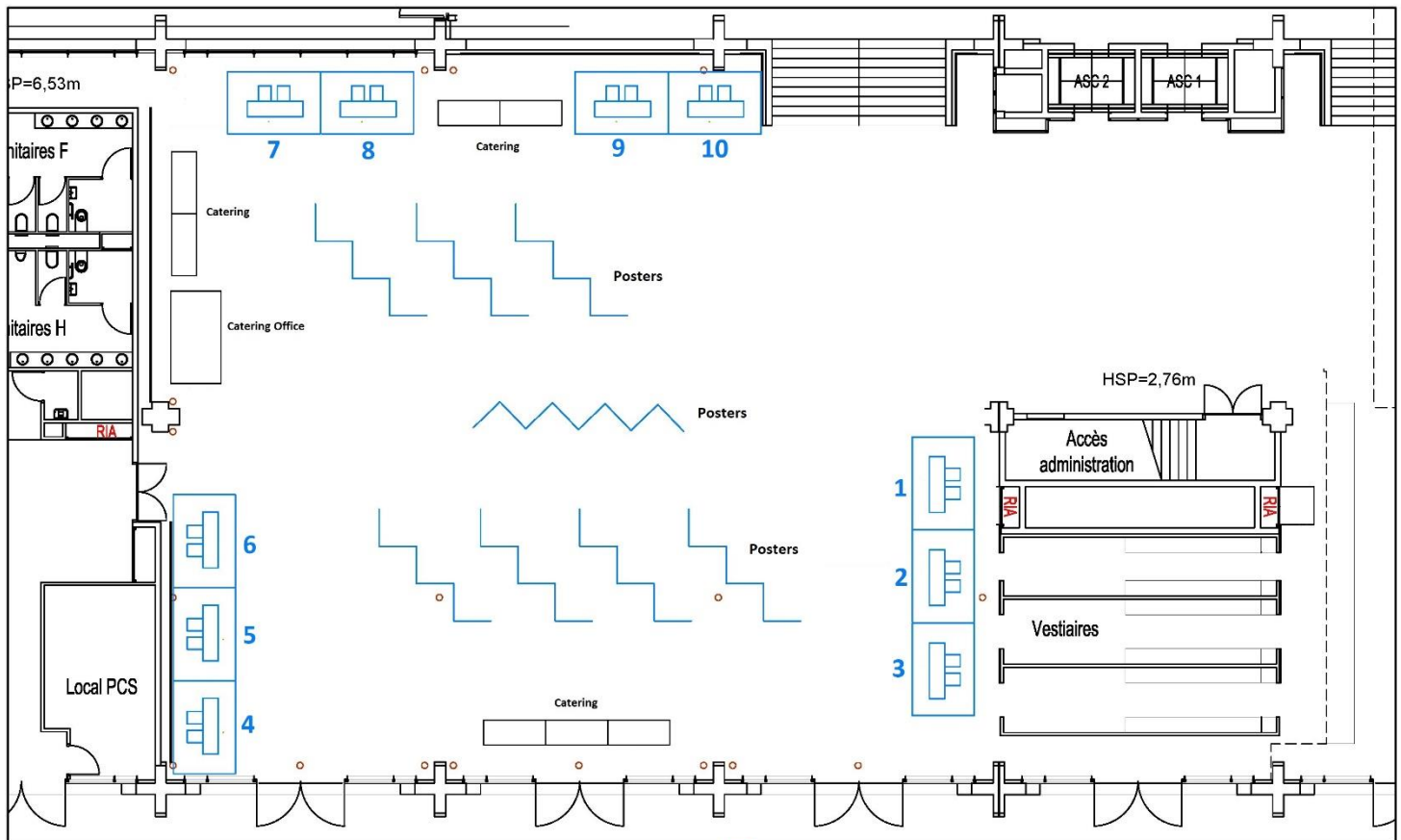

ALLOCATION OF EXHIBITION SPACE

Space will be allocated on a "first come, first served" basis. A completed Exhibition Booking Form should be emailed to ensure reservation of a desired location. Upon receipt of the Exhibition Booking Form, space will be confirmed and an invoice for the full amount due will be sent to the booker. Please note that two alternative choices should be clearly indicated on the booking form.

Space allocations will be made in the order in which booking forms are received.

ARTERY CONFERENCE SECRETARIAT

If you are interested in securing an exhibition package for your company, please do not hesitate to contact the Artery Conference Secretariat for further information.

The Conference Collective Ltd

8 Waldegrave Road

Teddington

Middlesex

Contact: Vera Hide - Conference Manager

Email: artery@conferencecollective.co.uk

Telephone: +44 (0) 20 8977 7997



The sponsorship opportunities above are available on a first-come, first-served basis.

If the above options do not meet your requirements, please do not hesitate to contact artery@conferencecollective.co.uk to enquire about bespoke sponsorship packages.

EU Customers: under reverse charge ruling EU customers account for VAT in their own country provided that they are able to supply a valid EU VAT number.

Invoices will be issued once a signed booking form agreement has been returned.

**ARTERY 2022 SPONSORSHIP AND EXHIBITION
BOOKING FORM AGREEMENT**

Wednesday 19 - Saturday 22 October 2022, Nancy, France

COMPANY DETAILS

Company:

Contact:

Position:

Address:

Postcode:

Country:

Telephone:

Email:

SPONSORSHIP PACKAGES

Item	Rate	Please tick
Friends of ARTERY Charity	€ 3,750	

EXHIBITION SPACE

Preferred Stand Choice	Stand Number
1 st Choice	
2 nd Choice	
3 rd Choice	

Each stand space includes 1 table, 2 chairs, and two complimentary registrations for the conference to include access to all the sessions, lunch/tea/coffee on Wednesday, Thursday, Friday and Saturday and conference materials. **Please note there is no lunch on Wednesday.**

ADDITIONAL CONFERENCE REGISTRATIONS

Each stand space includes two complimentary registrations for the conference. If you wish to book additional places for company personnel, please complete the section below.

I wish to book places at €320.00 per registration	Total: €
---	-----------------

CONFERENCE DINNER TICKETS

I wish to book additional tickets at €70 per ticket	Total: €
---	-----------------

TOTAL TO PAY: €

INVOICING DETAILS

COMPANY DETAILS

Company name:

Contact name:

Position within company:

Address:

Postcode:

Country:

Telephone:

Email:

Purchase Order No:

VAT No:

Signature

Date

EXHIBITION TERMS & CONDITIONS

By returning this booking form, you accept the contract terms and conditions (listed in this Exhibition Prospectus) and agree to abide by the terms and conditions for the Conference. The person named above is authorised to book this space on behalf of the applicant/company. The Exhibition Booking Form will be held as a valid liable contract, by which both parties will be bound.

Please complete this form and return to:

Vera Hide - ARTERY 22 Conference Secretariat
c/o The Conference Collective Limited
8 Waldegrave Road
Teddington
Middlesex TW11 8HT
UK

Email: artery@conferencecollective.co.uk

Tel: +44 (0) 20 8977 7997

Terms & Conditions

The Booking Form constitutes an agreement by the Exhibitor to exhibit at ARTERY 2022 on these terms and conditions only. The Organisers reserve the right to accept or refuse such agreement at its sole discretion.

In the event that the Organisers accept the Exhibitor's offer, the Organiser will provide written confirmation of the booking, and this will create a legally binding contract between the Exhibitor and the Organiser on these terms and conditions only to the exclusion of all others (this 'Agreement').

All bookings of exhibition packages are administered on a first come, first-served basis. Each stand includes complimentary registrations for two exhibition personnel to include access, refreshments at official Conference break times & conference materials. A completed Exhibition Booking Form should be emailed to ensure reservation of a desired location. Upon receipt of the Exhibition Booking Form, space will be confirmed, and an invoice will be mailed. Please note that three alternative choices should be clearly indicated on the application form. Space allocations will be made in the order in which application forms are received.

Payment

On providing such written confirmation to the Exhibitor, the Organiser will issue its invoice to the Exhibitor in respect of the Exhibitor Fee. The Exhibitor shall make full and final payment to the Organiser no later than 30 days following receipt of the invoice.

Payments should be made in EUROS.

Terms

This Agreement commences on the date of the Organiser's written confirmation of the booking and shall terminate at the end of ARTERY 2022 except when expressly provided otherwise in these terms.

Cancellation clause

Cancellation of Exhibition Booking must be made in writing to The Exhibition Manager, ARTERY 2022, c/o The Conference Collective, 8 Waldegrave Road, Teddington, Middlesex TW11 8HT and can be emailed to artery@conferencecollective.co.uk. If the Exhibitor cancels this Agreement, the Organiser shall refund (subject to any costs as set out below) to the Exhibitor a percentage of the fees determined in accordance with the following:

- if cancellation/reduction is received between 26 September 2022 and 7 October, the organisers shall retain 80% of the agree package amount
- and if cancellation/reduction is received after 8 October, the organisers shall retain 100% of the agreed package.

The exhibition fee (where applicable) will be refunded after the conference.

The Organiser shall be entitled to retain from any refunded fees a sum equivalent to its actual administration expenses, the costs of materials and any costs to which the Organiser has committed when the Exhibitor cancels this Agreement. If the conference is cancelled by the Organiser (other than as a result of events beyond the reasonable control of the Organiser), the Organiser shall refund the fee paid by the Exhibitor.

Insurance

While every precaution is taken to protect your property during the event, the Organisers are not responsible for any loss or damage, and we strongly recommend that you take out appropriate insurance cover. The Organisers accept no responsibility for any loss sustained by exhibitors from theft, fire damage or any third party.

Exhibitors are also responsible for insuring against any legal liability incurred in respect of injury or damage to property belonging to third parties. In addition to this exhibitor should protect their expenditures against abandonment and cancellation or curtailment of the event due to reasons beyond the Organiser's control.

Security

The Organisers cannot be held responsible for the loss or damage to exhibitors' property. Exhibitors are advised not to leave their stand unattended at any time especially if there are portable and valuable items on the stand.

Exhibition set up and breakdown

Exhibitors must ensure that their stand is set up and dressed by the times specified in the Exhibitor Manual. The only activities permissible on the day of the Conference are displaying brochures or the set-up of any valuable equipment, which for security reasons you do not want to leave unattended overnight. Exhibition stands must not be broken down before 14.00 on Saturday 22 October 2022, the last day of the Conference.

Exhibitors' responsibilities

All exhibiting companies are responsible for their stand. Due consideration must be given to the safety of the stand throughout the event and that any actions or inactions do not give rise to accidents, injuries or an unsafe working environment so far as is reasonably practicable.

Accessibility

The current EU regulations state that disabled persons must be afforded the same opportunities as able-bodied persons. This includes the ability to attend exhibitions and view any exhibits. To this end, exhibitors are advised to ensure that their stand is easily accessible to visitors in wheelchairs.

Liability clause

The Organiser shall not be liable for any failure to fulfil this contract where failure is caused by supervening circumstances including weather, fire, flood, earthquake, travel, transport delays, war, riots, acts of terrorism or events which, without fault of either party, render fulfilment impossible.

The Organiser's obligations

The Organiser will:

- Organise the ARTERY 2022 conference to a high standard and to the best of its ability
- Ensure the Exhibitor benefits from all elements of the confirmed Exhibition Package
- Not do or knowingly permit to be done anything which is prejudicial to the good image of the Exhibitor

Exhibitor's obligations

Stands must be staffed during key exhibition times, including refreshment breaks, lunch breaks and poster viewing sessions. Companies wishing to offer hospitality in addition to the Conference social programme must contact the Conference Secretariat: artery@conferencecollective.co.uk.

Any additional social events must not clash with the official Conference Social Programme and is subject to the agreement of the Organiser.

The Exhibitor (including its officers, employees, contractors and agents) and the exhibition stand must comply in all respects with all applicable laws, regulations, and rules and conditions of the Venue relevant to it, and with any relevant trade codes of practice.